



Product description

The Mobile Stand Base is the basic mobile stand for flat panel displays up to 86" or a maximum weight of 120kg/264 lb.

The stand can be assembled at three different heights.

Article number	Product Description	Weight range	
481A98001	BalanceBox® Mobile Stand Base	120 kg	264 lb

Features:

- Mobile Stand with 3 set mounting heights
- For panel sizes up to 86"
- Max load 264 lb /120 kg
- Large 4" / 100mm diameter lockable non-marking casters for easy rolling
- VESA mount included, sizes 200x200 up to 800x600mm
- Pen / laptop tray full width
- Easy and quick assembly
- Mounting hardware for panels included
- Easy access to the panel also for wheelchair users
- Compact packaging, suited for parcel transport

Material:

- Steel

Finish:

- Powder coated black RAL9005 textured

Certifications

- CE



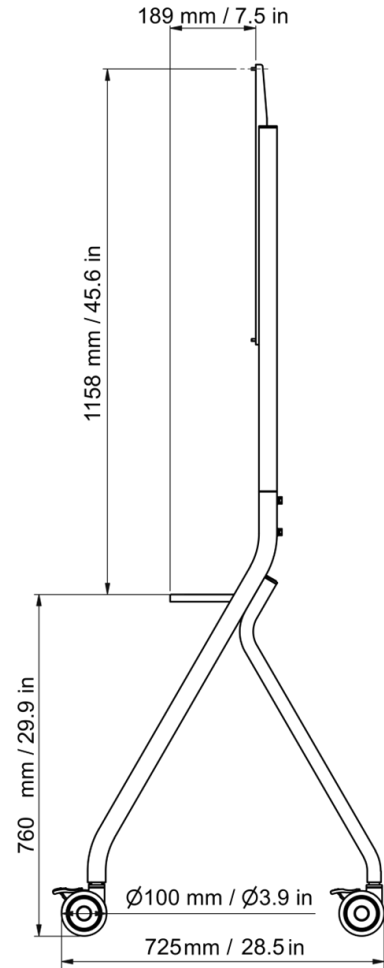
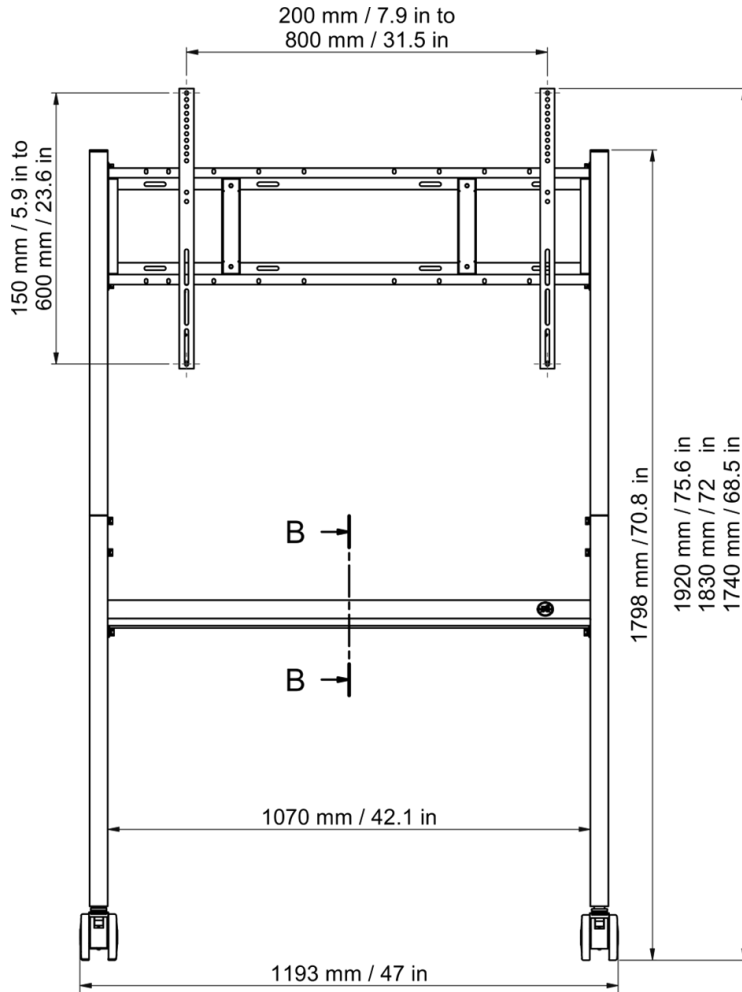

Download technical drawings here

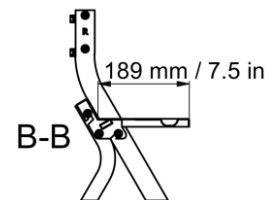

Dimensions

	Shipping dimensions		Pallet quantity: 14 each	
Height	163 mm	6.4 inch	2400 mm	94.5 inch
Width	1146 mm	45.1 inch	730 mm	28.75 inch
Depth	717 mm	28.2 inch	1160 mm	45.7 inch
Shipping weight	±22,3 kg	±49 lb		
Product weight	±19,3 kg	±42.5 lb		