



Article number: 481A50

Mobile stand for
BalanceBox® 650

US



EU



Product description

The Mobile Stand for BalanceBox® 650 is a heavy-duty mobile base designed for use with the BalanceBox 650 adjustable wall mount.

Article number	Product Description	Load capacity	
481A50 + 484A17	Mobile stand for BalanceBox 650 in combination with BalanceBox-II Light	34 – 68 kg	75 – 149.5 lb
481A50 + 484A18	Mobile stand for BalanceBox 650 in combination with BalanceBox-II Medium	67 – 127 kg	148 – 279 lb
481A50 + 484A19	Mobile stand for BalanceBox 650 in combination with BalanceBox-II Heavy	94 – 162 kg	207 – 356 lb
481A50 + 484A20	Mobile stand for BalanceBox 650 in combination with BalanceBox-II X-Heavy*	174 – 220 kg	383.6 – 485 lb

Calculate the combined weight of the panel, VESA bracket and any accessories to determine the required BalanceBox 650 model.
*The combination of the #481A50 Mobile stand for BalanceBox 650 with the #484A20 BalanceBox-II X-Heavy is CE only!

Material and Finish:

- Frame: steel, powder coated, black textures (RAL9005)

Compatibility:

- The Mobile stand for BalanceBox 650 is compatible with panels up to 136" if the weight of the panel does not exceed the maximum weight capacity of the BalanceBox 650-II.

Certificates

- CE
- TÜV Baumuster geprüft (62368-1)
- UL/IEC/CSA (62368-1)



Compatible with

Article number	Product description
484A17	BalanceBox® 650-II Light
484A18	BalanceBox® 650-II Medium
484A19	BalanceBox® 650-II Heavy
484A20	BalanceBox® 650-II X-Heavy



US



EU

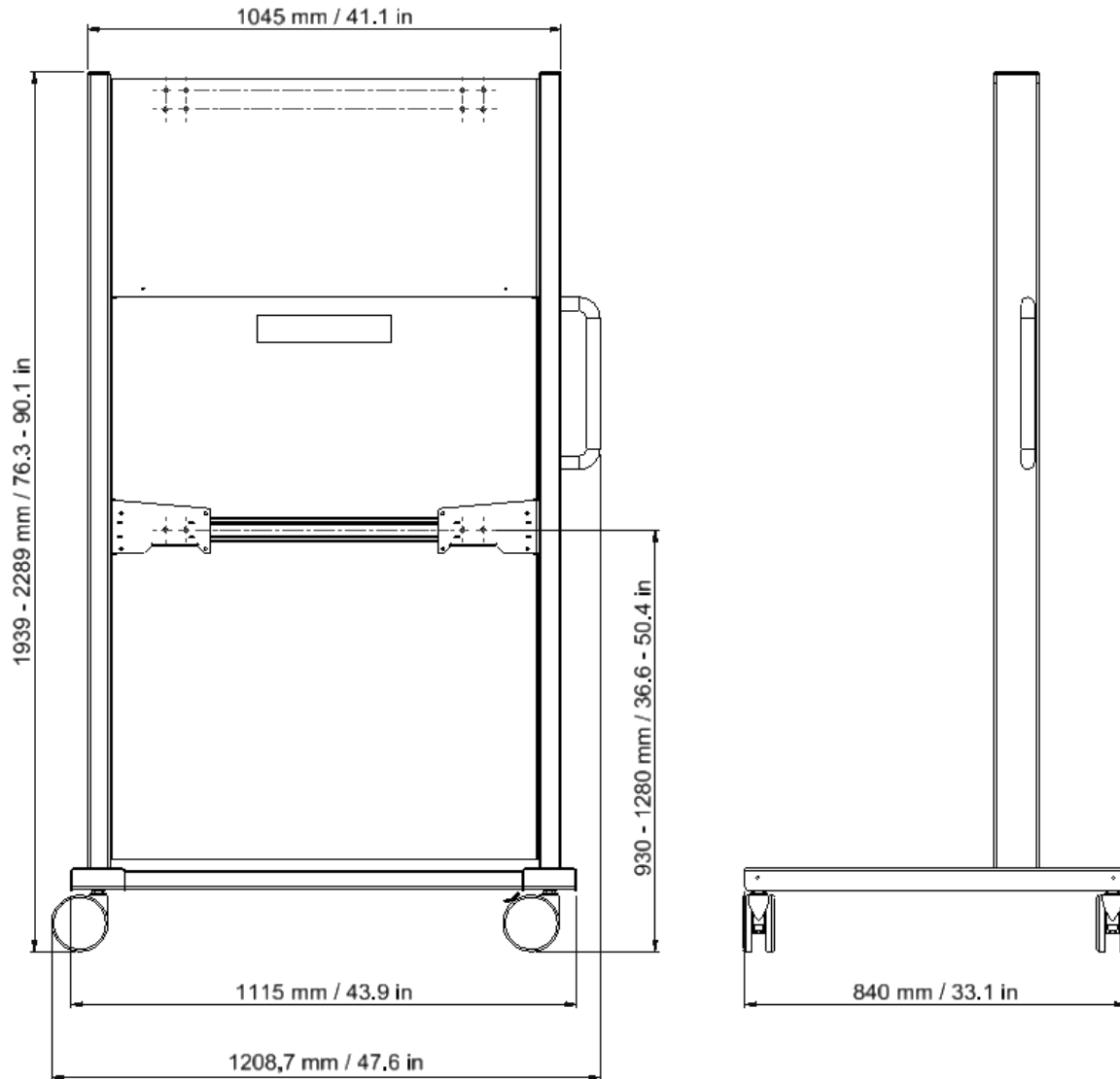

Download technical drawings here



EU



US

Dimensions

Shipping dimensions		
Length	1900 mm	47.5 inch
Width	1200 mm	47.25 inch
Height	300 mm	12 inch
Shipping weight	±100 kg*	±220 lb*
Product weight	±71 kg	±168 lb

*Shipping weight: mobile stand + pallet